

Mastery Professional Development

Multiplication and Division



2.16 Multiplicative contexts: area and perimeter 1

Teacher guide | Year 4

Teaching point 1:

Perimeter is the distance around the edge of a two-dimensional (2D) shape.

Teaching point 2:

Perimeter is measured in units of length and can be calculated by adding together the lengths of the sides of a 2D shape.

Teaching point 3:

Multiplication can be used to calculate the perimeter of a regular polygon; when the perimeter is known, side-lengths can be calculated using division.

Teaching point 4:

Area is the measurement of the surface of a flat item.

Teaching point 5:

Area is measured in square units, such as square centimetres (cm²) and square metres (m²).

Teaching point 6:

The area of a rectangle can be calculated using multiplication; the area of a composite rectilinear shape can be found by splitting the shape into smaller rectangles.

Overview of learning

In this segment children will:

- be introduced to the concept of perimeter and learn to measure perimeter using a piece of string
- recap units of measurement, focusing on centimetres and metres, and understand that perimeter is measured in units of length
- measure perimeters using countable units, such as sticks or grid paper
- learn that perimeter is calculated by adding together all of the side-lengths of a shape; the order does not matter
- use multiplication to find perimeters, and use division to find unknown side-lengths, when working with regular polygons
- be introduced to the concept of area, and learn that area can be calculated by counting square units
- understand that making a shape into whole square units is a useful way to calculate the area
- be introduced to square centimetres (cm²) and square metres (m²)
- calculate areas of rectangles by multiplying together the length and the width, and use division to find unknown side-lengths when the area of a rectangle is known
- find the area of composite rectilinear shapes by splitting them into smaller rectangles.

Teaching point 1 begins by introducing the concept of perimeter. Irregular shapes are used initially in order to help children focus on the concept. Step 1:2 highlights the importance of specifying exactly what perimeter is, and what it is not, to ensure that children are measuring correctly in the steps that follow. Once children are confident with the concept of perimeter, *Teaching points 2* and *3* move on to measuring and calculating the perimeter of 2D shapes. *Teaching point 2* links to earlier learning on commutativity (see *Spine 1: Number, Addition and Subtraction*, segment 1.11) to understand that the lengths can be added in any order.

Teaching point 3 moves from addition to multiplication, with children learning to use multiplication to calculate the perimeter of shapes with more than one side of the same length. Counters are used here to help children visualise the calculations. Next, division is used to calculate unknown side-lengths when the perimeter is given. This knowledge is then extended to apply to other regular polygons, building to an understanding that multiplication and division rules can be used to find the perimeter or side-lengths of any regular polygon.

Teaching point 4 introduces the concept of area, repeating a task that was carried out in *Teaching point 1* of physically touching objects in the classroom to understand the difference between perimeter and area. It is essential that children understand this difference before moving on. Grids are then used to calculate area by counting the number of square units. When using square units to calculate area, it is important that children are able to move or combine squares to create a shape that can be easily counted. This ability to visualise and manipulate shapes will be valuable as the segment develops.

Teaching point 5 introduces square centimetres and square metres, and the units cm² and m² are used for the first time.

Teaching point 6 involves using multiplication to calculate the area of rectangles. It is important that children understand what is represented by the numbers they are multiplying; teachers should revisit this throughout the teaching point using the suggested stem sentences. In a similar process to that used for perimeter (*Teaching point 3*), division is then used to find unknown side-lengths when the area is known. Finally the skills used throughout the segment are combined to find the area of rectilinear

shapes by splitting them into smaller rectangles and adding together the total areas. Children should be encouraged to use the correct units of measurement throughout.





Note: in representations, measurements have been drawn proportionally correct but scaled to fit the available space.

An explanation of the structure of these materials, with guidance on how teachers can use them, is contained in this NCETM podcast: www.ncetm.org.uk/primarympdpodcast. The main message in the podcast is that the materials are principally for professional development purposes. They demonstrate how understanding of concepts can be built through small coherent steps and the application of mathematical representations. Unlike a textbook scheme they are not designed to be directly lifted and used as teaching materials. The materials can support teachers to develop their subject and pedagogical knowledge and so help to improve mathematics teaching in combination with other high-quality resources, such as textbooks.

Teaching point 1:

Perimeter is the distance around the edge of a two-dimensional (2D) shape.

Steps in learning

	Guidance	Representations
1:1	<p>This teaching point introduces the concept of perimeter. Before starting to explore perimeter, briefly review measurement of straight lines, including real objects (such as the height of a desk, the width of the whiteboard etc.) in centimetres and/or metres. Next ask children to run their finger around the edge of objects in the classroom, such as a whiteboard or a desk top, starting in one corner and stopping when they have returned to the starting point. Tell them that the distance around the outside of a flat shape is called the perimeter. This will be contrasted later when children are introduced to the concept of surface area and will run their finger or hand across the whole of the surface, not just the edge.</p> <p>Now explore a real-life example involving perimeter, for example a caterpillar walking around the edge of a leaf. Using a real or paper leaf, move a picture of a caterpillar around the outside of the leaf.</p> <p>Next place a piece of string around the leaf and cut the string to the exact length of the perimeter. Stretch out the piece of string and explain that this is the same length as the distance around the edge of the leaf. Encourage children to check this by drawing around the leaf and laying the string onto the drawn outline. Confirm that it is the same length. Discuss whether the string looks longer when it is stretched out or when it is in the shape of the</p>	<p>Leaf 1:</p> <p><i>'The caterpillar walks around the edge of the leaf.'</i></p>   <hr/> <ul style="list-style-type: none"> <i>'The distance around the edge of the leaf is its perimeter.'</i> <p>Leaf 2:</p> <p><i>'Now the caterpillar walks around this leaf.'</i></p>   <hr/> <ul style="list-style-type: none"> <i>'The distance around the edge of the leaf is its perimeter.'</i>

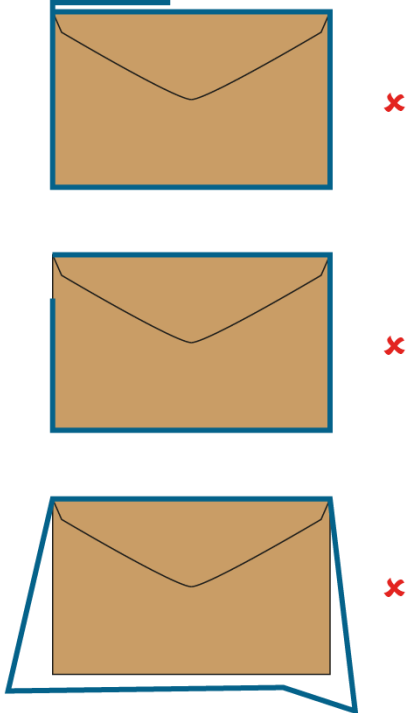
<p>leaf; direct children to the conclusion that they are both the same length.</p> <p>Use this stem sentence to introduce the term 'perimeter': 'The distance around the edge of the ___ is its perimeter.'</p> <p>Repeat the process, using a piece of string to measure the perimeter of other 2D shapes such as an envelope or a paper plate.</p> <p>Now, using a different leaf, cut a piece of string to the same length as its perimeter. Ask children whether the distance around the edge of the second leaf is longer, shorter or the same as the first leaf. Guide them to the conclusion that they can work this out by lining up the two pieces of string and comparing them.</p> <p>To deepen understanding of the concept of perimeter, you could walk around the perimeter of the playground or the school hall together.</p> <p>Continue to use the stem sentence to describe the perimeter.</p>	<p>Comparing perimeters:</p> <p><i>'Is the distance around the edge of leaf 2 longer, shorter or the same as the distance around the edge of leaf 1?'</i></p>  <ul style="list-style-type: none"> <i>'The distance around the edge of leaf 2 is longer than the distance around the edge of leaf 1.'</i>
<p>1:2 It is important that children understand what a perimeter is and what it is not. You could present some examples of lengths that are not a perimeter, such as:</p> <ul style="list-style-type: none"> a length that is more than once around the outside of a shape a length that is less than once around the outside of a shape a length that does not exactly follow the outside of a shape. <p>Emphasise that the end point must be the same as the starting point and that the line must exactly follow the outline of the shape/object.</p> <p>Encourage children to draw the perimeter around a range of objects. Lay objects onto a sheet of plain paper and ask children to draw around the</p>	

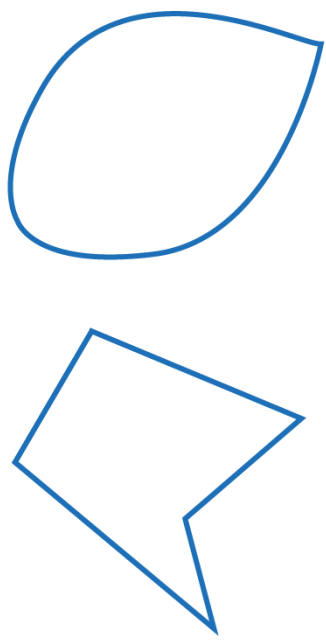
	<p>objects, or print different shapes onto paper and ask children to draw around the outline of the shapes. Use a mixture of irregular images and geometric shapes.</p> <p>Next ask children to use string to measure the perimeter of the shapes. You could ask children to predict which shapes they think will have larger or smaller perimeters, and then check their guesses by stretching out the pieces of string and comparing them.</p>	
<p>1:3</p>	<p>Now introduce the idea that different shapes can have the same perimeter. Use a piece of string to measure the perimeter of one shape, and then use the same piece of string to create a different shape. Ensure that the 'new' shape is closed. Ask children:</p> <ul style="list-style-type: none"> • <i>'What's the same?'</i> (perimeter) • <i>'What's different?'</i> (shape) <p>Using a piece of string tied into a loop, children could create a variety of shapes that have the same perimeter. This could also be done on a larger scale using loops of rope on the floor.</p>	<p>Different shapes with the same perimeter:</p> 

1:4

Finish this teaching point by considering how you might compare perimeters without using pieces of string. Place a large sheet of paper on the floor and ask children to walk around the outside, counting how many steps it takes them to travel around the perimeter. Make sure they walk 'toe-to-heel' with no gap between each step. Now ask an adult to walk around the outside of the shape and compare how many steps it takes them, to draw attention to the importance of using the same unit when comparing perimeters.

- 'Bhav says that her shape has the longest perimeter.'
- 'Kirti says that her shape has the longest perimeter.'
- 'Liz says that both shapes could have the same perimeter.'

'Who is right? Explain your answer.'

Bhav

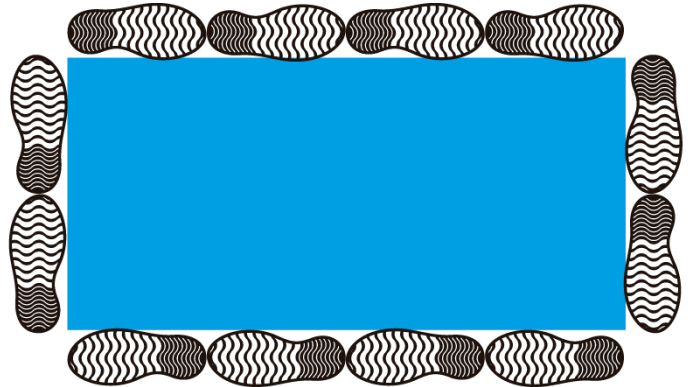

Kirti

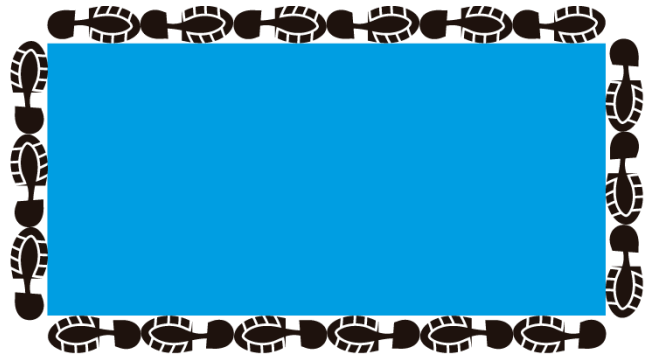

Teaching point 2:

Perimeter is measured in units of length and can be calculated by adding together the lengths of the sides of a 2D shape.

Steps in learning**Guidance**

2:1 At the end of the last teaching point children learnt that the same unit of measurement must be used if perimeters are to be compared. This teaching point introduces the use of centimetres and metres as standard measures that are universally recognised, so that perimeters can be given a value and compared.

To begin with, ask children how they might describe the perimeter of a shape. Look for descriptions where children use the word 'length'. Confirm that perimeter is a measurement of length and remind children that the units of length are millimetres, centimetres, metres and kilometres. Use the full terms initially, and then remind children that we can abbreviate these terms to mm, cm, m and km.

Using the leaf example from step 1:1, repeat the process of cutting a piece of string to the length of the distance around the edge of the leaf, then measure the piece of string using a ruler. Use the following stem sentence: **'The perimeter of the ___ is ___ cm.'**

Because a ruler is a straight piece of equipment, ensure children understand that perimeters are not always horizontal and straight, and that using a ruler is just one way to measure. You could demonstrate this by using a flexible tape measure or a trundle wheel to measure longer perimeters.

Representations

Standard units of length:

Unit	Abbreviation
millimetre	mm
centimetre	cm
metre	m
kilometre	km

Measuring leaf 1:

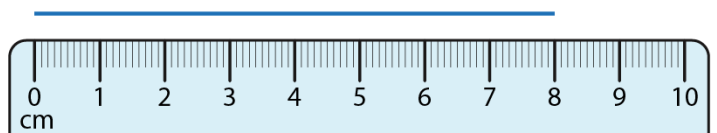

- *'The perimeter of the leaf is 8 cm.'*

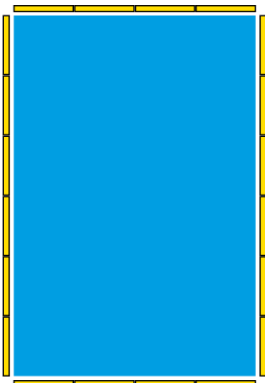
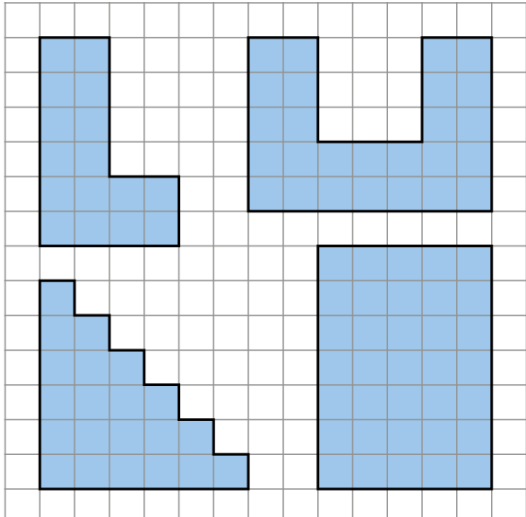
	<p>Use the following generalised statement: 'Perimeter is measured in units of length.'</p> <p>Ask children to use string to measure perimeters of various shapes and then use a ruler to confirm the length of the string. Continue to use the stem sentence to describe the length of the perimeter.</p> <p>At first you may want to use shapes whose perimeters are in whole centimetres.</p>	
<p>2:2</p>	<p>Next engage children in calculating perimeters using countable units such as sticks or grid paper.</p> <p>Place small sticks around the edge of shapes and ask children to work out the perimeter by counting the number of sticks. Ensure the sticks are all the same length.</p> <p>Then print or draw shapes onto grid paper, and ask children to count the number of squares around the outside of the shapes to find their perimeters.</p> <p>When counting squares on a grid, a possible error children may make is to include the corner squares, leading to an incorrect perimeter. Therefore this method shouldn't be used until the concept of perimeter being a length is well-established: it is the length of one side of each square that is being counted, not the whole square itself. The <i>dòng nǎo jīn</i> problem on the next page addresses this.</p>	<p>Finding the perimeter using countable units:</p> <ul style="list-style-type: none"> 'What is the perimeter of this rectangle? Count the sticks.'  <ul style="list-style-type: none"> 'What is the perimeter of each shape? Count the squares.' 

Dòng nǎo jīn:

- 'Sally says the perimeter of this garden is 24 units.'

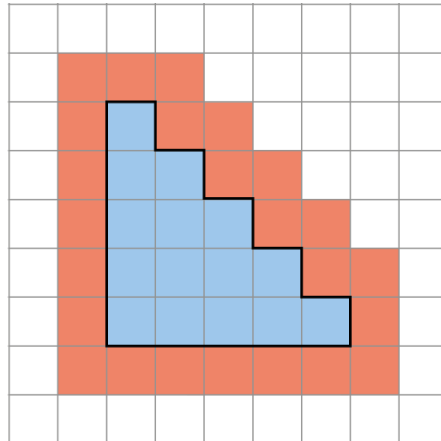

- 'Felicity says the perimeter of the garden is 20 units.'

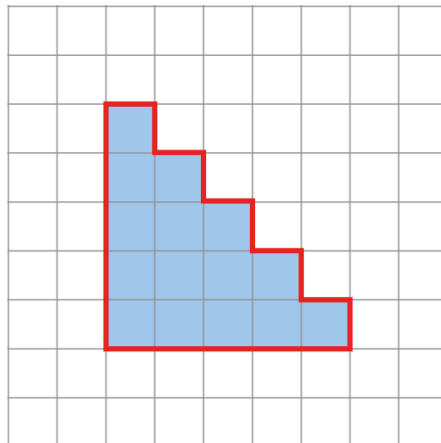

'Who is correct? Explain your answer.'

2:3

Once children are confident using sticks and grids to measure perimeters, move on to using given information to calculate perimeters, without the need to count units.

Introduce a simple 2D shape such as a triangle. Encourage children to discuss what the perimeter of the shape is and why. Share ideas and establish how to calculate the perimeter. Come to the conclusion that the perimeter can be calculated by adding the lengths of the sides.

You could ask children:

- 'Does the order in which you add the sides matter?'
- 'Do all of the sides need to be included in the calculation?'

Draw out the answers that the perimeter is the distance all the way around a shape and so all sides must be included, but that the order does not matter. You could ask children to write the addition equation in as many different ways as they can, drawing attention to the fact that the answer is always the same (see *Spine 1: Number, Addition and Subtraction*, segment 1.11).

Repeat using different shapes with given side-lengths, working towards the following generalisation: **'You can use addition to find the perimeter of a shape.'**

Introduce the use of 'P' to mean 'perimeter', for example:

$$P = 6 \text{ cm} + 3 \text{ cm} + 4 \text{ cm}$$

$$P = 13 \text{ cm}$$

- 'What is the perimeter of this triangle?'

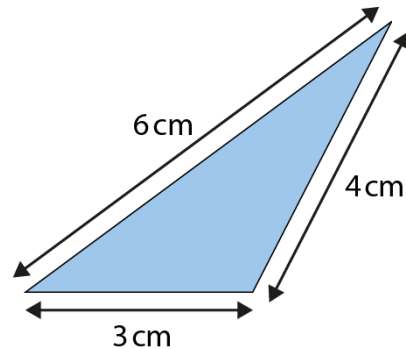

$$\begin{aligned} \text{perimeter} &= 6 \text{ cm} + 4 \text{ cm} + 3 \text{ cm} \\ &= 13 \text{ cm} \end{aligned}$$

- 'We can write the side-lengths in any order.'

$$6 \text{ cm} + 4 \text{ cm} + 3 \text{ cm} = 13 \text{ cm}$$

$$6 \text{ cm} + 3 \text{ cm} + 4 \text{ cm} = 13 \text{ cm}$$

$$4 \text{ cm} + 6 \text{ cm} + 3 \text{ cm} = 13 \text{ cm}$$

$$4 \text{ cm} + 3 \text{ cm} + 6 \text{ cm} = 13 \text{ cm}$$

$$3 \text{ cm} + 4 \text{ cm} + 6 \text{ cm} = 13 \text{ cm}$$

$$3 \text{ cm} + 6 \text{ cm} + 4 \text{ cm} = 13 \text{ cm}$$

- 'What is the perimeter of each shape?'

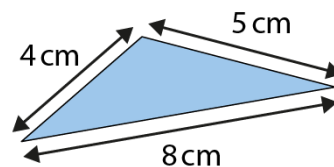

$$\begin{aligned} P &= 8 \text{ cm} + 4 \text{ cm} + 5 \text{ cm} \\ &= 17 \text{ cm} \end{aligned}$$

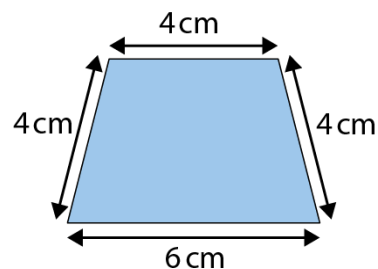

$$\begin{aligned} P &= 4 \text{ cm} + 4 \text{ cm} + 4 \text{ cm} + 6 \text{ cm} \\ &= 18 \text{ cm} \end{aligned}$$

2:4

Finish this teaching point by asking children questions that encourage them to consider which units have been used, and how they might use properties of shapes to work out perimeters if some of the dimensions are missing. For questions like Example 1 opposite, encourage children to give their answers in one of these formats:

- 'The perimeter of this shape is ___cm.'
- 'I do not have enough information to work out the perimeter of this shape.'

Example 1:

'Do you have enough information to work out the perimeter of this shape? If so, what is it?'

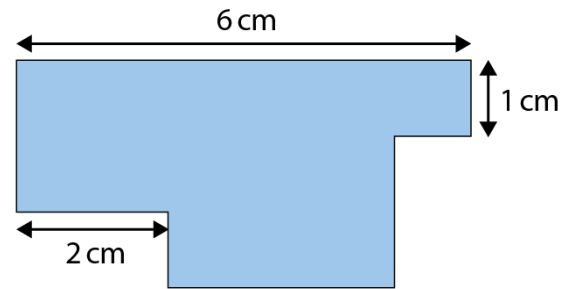

Example 2:

'True or false? The perimeter of shape A is longer than the perimeter of shape B.'

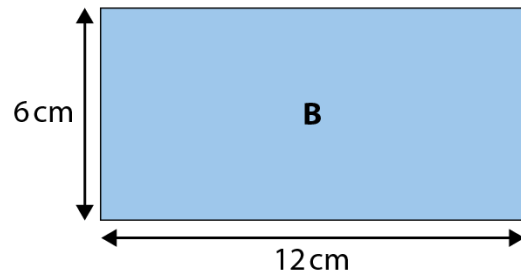
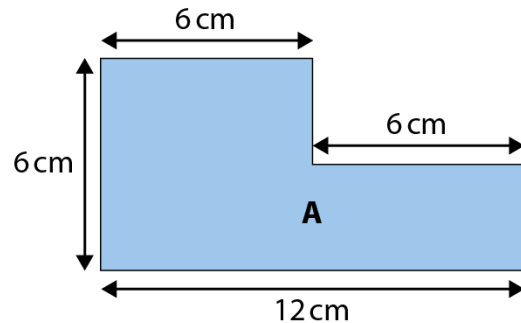

Example 3:

'Which of the answers below give the correct perimeter for this shape?'

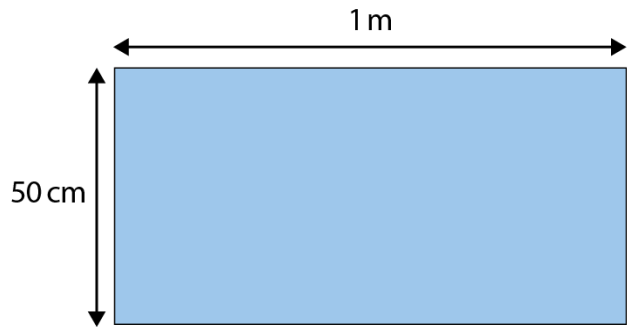

	Correct (✓) or incorrect (✗)
51 cm	
3 m	
102 cm	
300 cm	
1 m 50 cm	
210 cm	

Dòng nào jīn:

'The perimeter of this triangle is 22 cm. What is the missing side-length?'

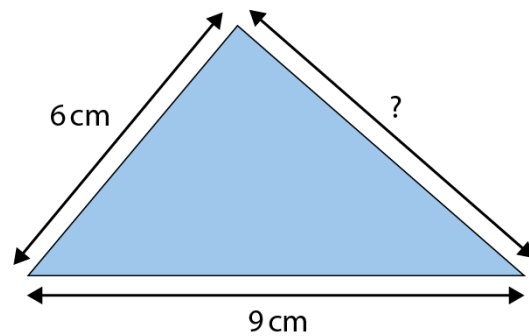

Teaching point 3:

Multiplication can be used to calculate the perimeter of a regular polygon; when the perimeter is known, side-lengths can be calculated using division.

Steps in learning

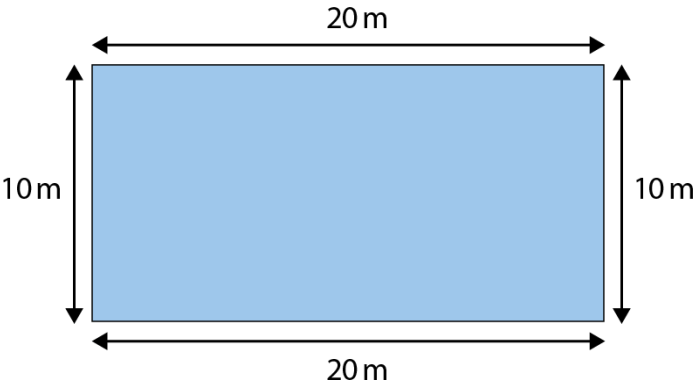
	Guidance	Representations
3:1	<p>In this teaching point, children will start to make links with multiplication when finding perimeters and with division when finding unknown side-lengths, where shapes have more than one side of the same length.</p> <p>Start by showing children an image of a rectangle, such as the example opposite. You may like to use a context such as a playing field or a swimming pool. Suggest to them that you might want to measure the perimeter if someone is jogging or swimming along the edge of the field or pool. Then ask what they know about rectangles. Draw out the answer that there are two pairs of sides with the same length.</p> <p>Next ask children to write out the calculation they would use to calculate the perimeter.</p> <p>For the example opposite, some will write:</p> $P = 20 \text{ m} + 10 \text{ m} + 20 \text{ m} + 10 \text{ m}$ $= 60 \text{ m}$ <p>Identify any examples where children have presented this as:</p> $P = 20 \text{ m} + 20 \text{ m} + 10 \text{ m} + 10 \text{ m}$ $P = 60 \text{ m}$ <p>(If they have not, introduce this yourself.) Ask children what repeating groups they can see. Draw attention to the fact that, as some of the sides are the same as others, there is repeated addition.</p> <p>Some children might think that you must add up the lengths in the order</p>	<p>Finding the perimeter of a rectangle:</p> 

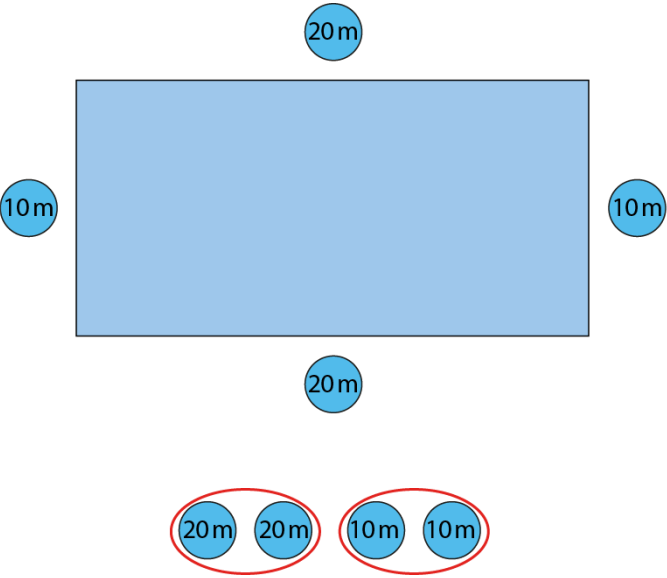
	<p>that you travel around the shape (revisit step 2:3 to counter this misconception). Carry out both calculations to show that the perimeter is the same regardless of the order in which you add up the length of the sides.</p>
<p>3:2 In this step we begin to make links to multiplication, using counters to reveal the structure of the calculation. Use counters marked with the values of the side-lengths placed next to the relevant side of the rectangle. Ensure that you use only one unit of measurement for each shape (e.g. metres) at this stage so that children can focus on the multiplicative structure of the calculation.</p> <p>Then line up the counters in two different ways to show the ways the numbers can be ordered:</p> $20\text{ m} + 10\text{ m} + 20\text{ m} + 10\text{ m}$ $= 20\text{ m} + 20\text{ m} + 10\text{ m} + 10\text{ m}$ <p>Placing counters with the same value next to each other supports children when thinking algebraically. This prepares them for the next step.</p> <p>Next, group the counters by value, one group with two 20s and one group with two 10s. Use the counters to create an expression:</p> $2 \times 20\text{ m} + 2 \times 10\text{ m}$ <p>Relate this calculation back to the shape, asking:</p> <ul style="list-style-type: none"> • 'What does the "20" represent?' (the long side) • 'What does the "10" represent?' (the short side) • 'How many long sides are there?' (two) • 'How many short sides are there?' (two) <p>You may wish to label the sides as 'length' and 'width' to draw attention</p>	<p>Using multiplication to find the perimeter:</p>  $P = 2 \times 20\text{ m} + 2 \times 10\text{ m}$ $= 40\text{ m} + 20\text{ m}$ $= 60\text{ m}$

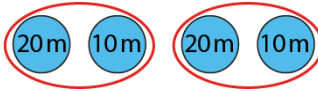
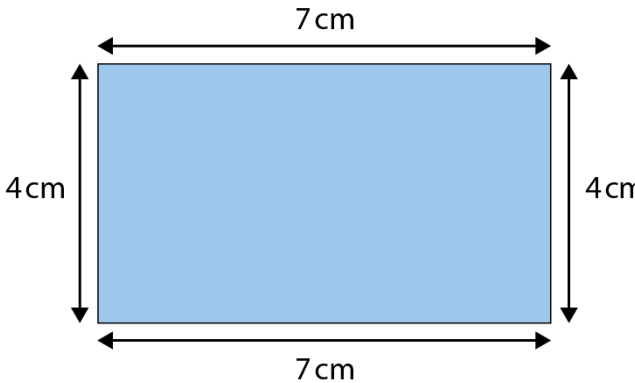
	<p>to how many sides of each type there are.</p> <p>Repeat these steps with other rectangles of different sizes. Work towards the following generalised statement: 'The perimeter of a rectangle is equal to two times the length of the long side plus two times the length of the short side.'</p>	
<p>3:3</p>	<p>Using the first rectangle from step 3:2, rearrange the counters to add the length of the long side and the short side and then multiply by two. Demonstrate this by visually grouping the counters, as shown opposite.</p> <p>Children can express this in words: <i>'First find the sum of the lengths of the short and long sides of the rectangle. Then multiply this sum by two.'</i></p> <p>Relate this calculation back to the shape, asking:</p> <ul style="list-style-type: none"> • <i>'What does the "20" represent? (the long side)</i> • <i>'What does the "10" represent? (the short side)</i> • <i>'What does the "30" represent? (the sum of the long side and the short side)</i> • <i>'Why is the perimeter 30×2?' (there are two groups of long sides and short sides)</i> <p>Provide children with rectangles of different sizes and ask them to use both methods to find the perimeter. They may like to use the visual grouping of counters to help at first.</p>	<div style="text-align: center;">  </div> <ul style="list-style-type: none"> • <i>'First find the sum of the lengths of the short and long sides of the rectangle. Then multiply this sum by two.'</i> $20 + 10 = 30$ $30 \times 2 = 60$ $P = 60 \text{ m}$ • <i>'Work out the perimeter of this rectangle. Use two different methods.'</i> <div style="text-align: center;">  </div> <p>Method 1:</p> $7 \text{ cm} + 4 \text{ cm} = 11 \text{ cm}$ $11 \text{ cm} \times 2 = 22 \text{ cm}$ $P = 22 \text{ cm}$ <p>Method 2:</p> $P = 7 \text{ cm} \times 2 + 4 \text{ cm} \times 2$ $= 14 \text{ cm} + 8 \text{ cm}$ $= 22 \text{ cm}$

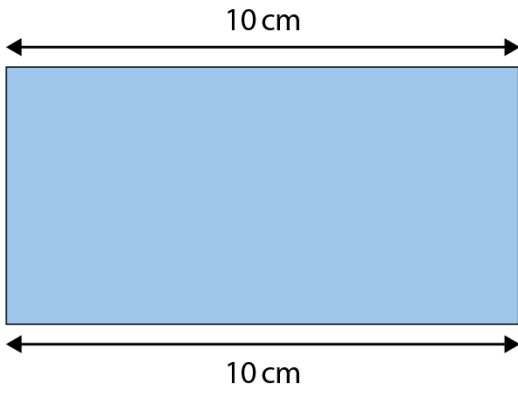
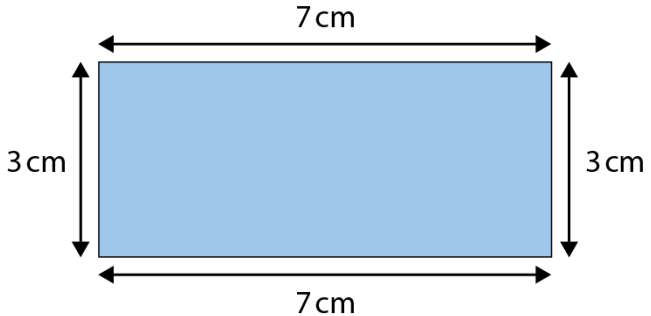
<p>3:4</p>	<p>Next develop the use of subtraction and division to find unknown side-lengths of a rectangle. Show children a rectangle with the perimeter and the long side-lengths given. Use subtraction to work out the combined length of the two unknown sides:</p> <p style="padding-left: 20px;">perimeter – two long sides = two short sides</p> <p>Ask children 'How could we work out the length of each short side?' Referring to the doubling and halving strategies learnt in segment 2.5 <i>Commutativity, doubling and halving</i>, work towards the answer that halving the two short sides will give the length of one short side.</p> <p>Repeat this step using different rectangles, providing the perimeter and one or more sides.</p>	<p><i>'The perimeter of this rectangle is 30 cm. What is the length of each short side?'</i></p>  <p>$30 \text{ cm} - 2 \times 10 \text{ cm} = 30 \text{ cm} - 20 \text{ cm} = 10 \text{ cm}$ $10 \text{ cm} \div 2 = 5 \text{ cm}$ short side = 5 cm</p>
<p>3:5</p>	<p>At this point, provide children with practice to apply what they have learnt, including both types of problem:</p> <ul style="list-style-type: none"> • provide side-lengths and ask children to find the perimeter • provide the perimeter and one or more side-lengths and ask children to find the missing side-lengths. 	<ul style="list-style-type: none"> • <i>'What is the perimeter of this rectangle?'</i> 

- 'The perimeter of this rectangle is 60 cm. How long are the long sides?'

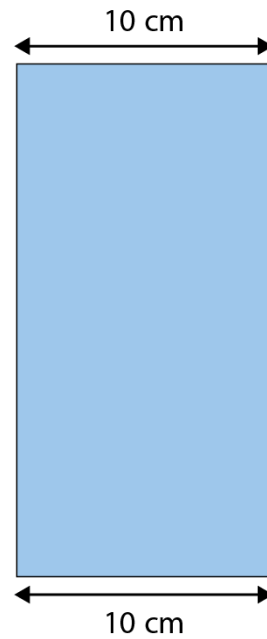

True/false style problem:

'Add a tick or cross in each column to show whether the statement is true or false.'

Length of one of the sides	Could have a perimeter of 60 cm	Could <u>not</u> have a perimeter of 60 cm
10 cm		
20 cm		
30 cm		
40 cm		
50 cm		

3:6

Next focus on regular polygons (shapes in which all angles are equal and all sides are equal) starting with a square. Remind children of the generalisation used for rectangles in step 3:2:

'The perimeter of a rectangle is equal to two times the length of the long side plus two times the length of the short side.'

Discuss how this rule might apply to a regular shape. Draw out the idea that all sides are the same length.

Using a square, as shown opposite, ask children to write down the perimeter as a repeated addition:

$$P = 12 \text{ m} + 12 \text{ m} + 12 \text{ m} + 12 \text{ m}$$

Then ask them how this could be recorded using multiplication:

$$P = 12 \text{ m} \times 4$$

Encourage children to practise finding the perimeters of squares by completing the table opposite.

Make links to the four times table by using the following generalisation:

'The perimeter of a square is four times the length of one of the sides.'

Now repeat these steps for an equilateral triangle. Work towards the following generalisation:

'The perimeter of an equilateral triangle is three times the length of one of the sides.'

- 'What is the perimeter of this square?'

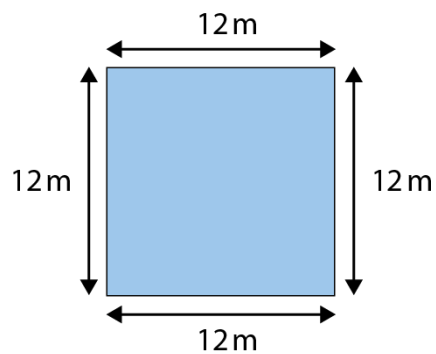

$$\begin{aligned} P &= 12 \text{ m} + 12 \text{ m} + 12 \text{ m} + 12 \text{ m} \\ &= 12 \text{ m} \times 4 \\ &= 48 \text{ m} \end{aligned}$$

- 'Complete the table.'

Number of sides	Length of side in cm	Perimeter
4	1	4
	2	8
4	3	
4		16
	5	20
4		24

- 'What is the perimeter of this equilateral triangle?'

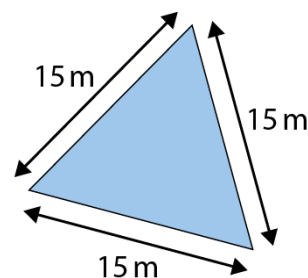

$$\begin{aligned} P &= 15 \text{ m} + 15 \text{ m} + 15 \text{ m} \\ &= 3 \times 15 \text{ m} \\ &= 45 \text{ m} \end{aligned}$$

3:7

The next step encourages children to identify the generalisation for working out the perimeter of any regular polygon, making the connection to how many sides it has. Explain clearly that these shapes have sides that are all the same length. It is important that children understand that these rules only apply to shapes that have sides of equal lengths.

Draw up a table giving the number of sides of a regular polygon and the calculation needed to find the perimeter, as shown opposite. Start with an equilateral triangle and a square.

Draw a regular pentagon (five-sided shape), including length measurements on the sides to show that they are all the same. If children need a reminder of the previous steps you could use counters to unitise, by placing equal value counters on each side of the shape and then rearranging the counters into a row, as in step 3:2. Encourage children to make the link that you need to add five lengths to find the perimeter of a five-sided shape. Use this information to complete the next row in the table.

Continue to draw regular polygons and repeat the steps above, adding to the table each time.

Once children are confident with the steps, use the following generalised statement: ***'To find the perimeter of a regular polygon, you multiply the length of one of the sides by the number of sides.'***

Perimeters of regular polygons:

Number of sides	Perimeter
3	length of one side \times 3
4	length of one side \times 4
5	length of one side \times <input type="text"/>
...	...

- 'What is the perimeter of this regular pentagon?'

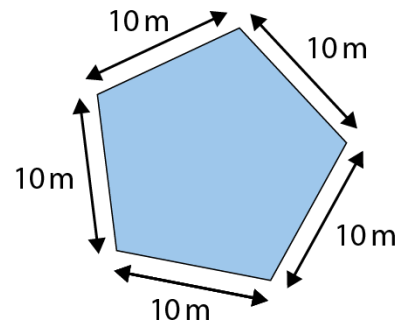

$$\begin{aligned} P &= 10\text{ m} + 10\text{ m} + 10\text{ m} + 10\text{ m} + 10\text{ m} \\ &= 5 \times 10\text{ m} \\ &= 50\text{ m} \end{aligned}$$

- 'What is the perimeter of this regular hexagon?'

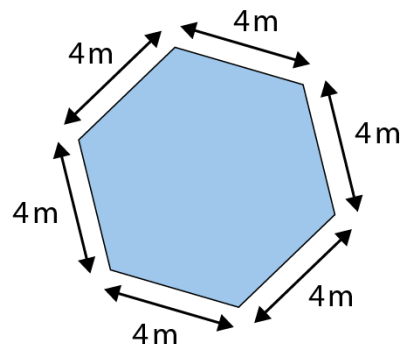

$$\begin{aligned} P &= 4\text{ m} + 4\text{ m} + 4\text{ m} + 4\text{ m} + 4\text{ m} + 4\text{ m} \\ &= 6 \times 4\text{ m} \\ &= 24\text{ m} \end{aligned}$$

3:8 Now encourage children to make links to division. Show that if you know the perimeter of a regular polygon, you can use division to find the length of each side. Using a table such as the one opposite, discuss what calculation you may need to use, coming to the following generalisation: **'If you know the perimeter of a regular polygon you divide it by the number of sides to find the length of one of its sides.'**

'Complete this table for regular polygons.'

Number of sides	Perimeter	Length of each side
3	24 cm	
4	24 cm	
6	24 cm	
8	24 cm	

3:9 To finish this teaching point, provide children with practice calculating missing numbers for regular polygons (number of sides, perimeter or length of the sides).
 You can use 'Always, sometimes, never?' questions to deepen children's understanding of how multiplication and division can be linked to perimeter. Use statements such as these:

- The perimeter of a triangle is three times the length of one of its sides. Always, sometimes, never?
- If a square has a perimeter of 5 m, you divide by 4 to find the length of one of its sides. Always, sometimes, never?
- A regular hexagon has a longer perimeter than a regular pentagon, if their sides are the same length. Always, sometimes, never?

'Complete this table for regular polygons.'

Number of sides	Perimeter	Length of each side
3	30 cm	10 cm
10	40 cm	4cm
5	50 cm	10 cm
10	60 cm	
	70 cm	7 cm
8		10 cm
10	90 cm	
	100 cm	10 cm

Dòng nǎo jīn:
'There are three triangular paving slabs. Every side of each triangle is 40 cm in length.'

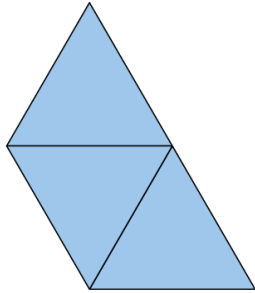

- *'Joseph thinks: "If I place these paving slabs like this, the perimeter is 40 cm × 9 as there are three triangles and each has three sides."*
- *'Becca thinks: "The perimeter is always 40 cm × 5 no matter how you place them."*

'What do you think?'

Teaching point 4:

Area is the measurement of the surface of a flat item.

Steps in learning

	Guidance	Representations
<p>4:1</p>	<p>This teaching point looks at the concept of area. Start by asking children to run their hand or finger over the surface of items in the classroom such as a table, a window or the cover of a book, ensuring that they touch all of the surface and do not miss any part of it. Draw children’s attention to the contrast with the activity they did in step 1:1, when they explored perimeter and ran their finger around the edge only. Conclude that area is the measurement of the <i>surface of a flat item</i>, as opposed to perimeter, which is the measurement of the distance <i>around the edge</i> of an item.</p>	
<p>4:2</p>	<p>Next look at which shapes could be used to cover these surfaces. Lay a variety of paper shapes over the surface of a table and discuss which shapes cover the table most effectively, i.e. with the fewest gaps. From the discussion, draw out the conclusion that squares are the best shape to use.</p>	<p>Using shapes to cover surfaces:</p>

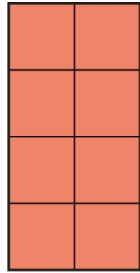
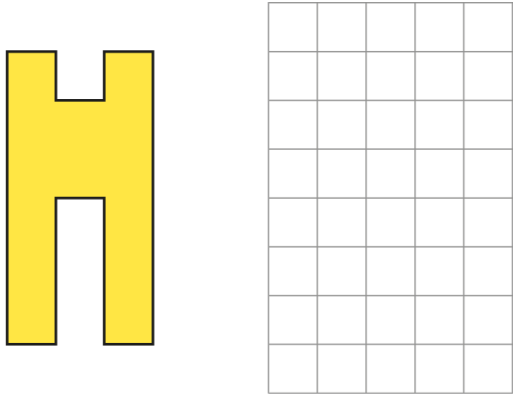
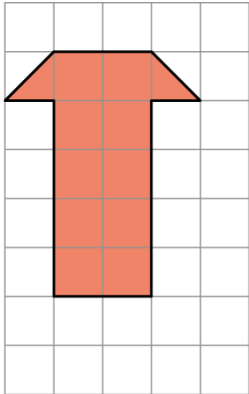
<p>4:3</p>	<p>Use the squares laid on the table to show that you can count the number of squares to give a value to the area. Use the following stem sentence: 'This shape has an area of ___ square units.'</p>	<p><i>'What is the area of this table?'</i></p>  <ul style="list-style-type: none"> <i>'This table has an area of eight square units.'</i>
<p>4:4</p>	<p>Now use a transparent squared grid to show how you can count squares for other shapes. Create paper shapes that fit under the grid to demonstrate various areas. Ensure the shapes are whole squares at this stage. Continue to use the stem sentence from the previous step.</p>	<p><i>'What is the area of this shape?'</i></p>  <ul style="list-style-type: none"> <i>'This shape has an area of fourteen square units.'</i>
<p>4:5</p>	<p>It is important children know that you can also count squares when the shape is not made up entirely of squares. Use an example where two halves (triangles) are put together to make a complete square.</p> <p>Repeat this using another shape that includes triangles that can be added together to make whole squares. Discuss with children how they can combine the triangles into squares and then count the squares to find the area.</p>	<p>Combining two triangles to make a square: <i>'What is the area of this shape?'</i></p>  <ul style="list-style-type: none"> <i>'This shape has an area of eleven square units.'</i>

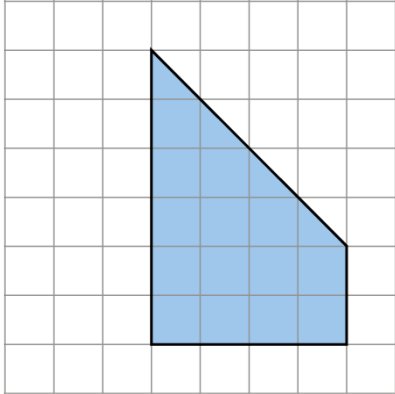
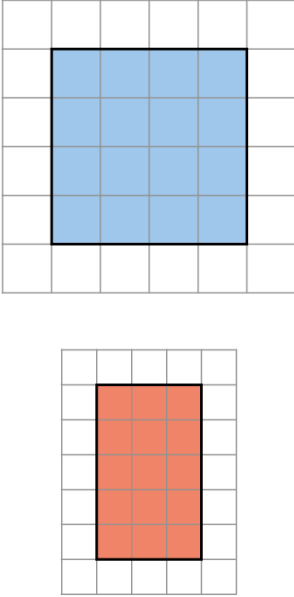
		<p>Combining more than two triangles to make squares: <i>'What is the area of this shape?'</i></p>  <ul style="list-style-type: none"> • <i>'This shape has an area of sixteen square units.'</i>
<p>4:6</p>	<p>Now introduce the idea that if you are to compare areas you must use the same-sized grid.</p> <p>Show two grids of different sizes, each with a different shape placed under it. Ask children <i>'Does one shape look bigger?'</i> Discuss the idea that it is difficult to tell just from looking. You could overlap the shapes to see if that helps to show which is bigger, but often it does not.</p> <p>Next ask children to count the squares on each grid to work out the areas of the shapes. Make it clear that these two areas cannot be compared because the grid sizes are different.</p> <p>Finally place the shapes under two grids that are the same size. Ask children to count the squares again and compare the areas to determine which shape is bigger.</p>	<p>Different sized grids: <i>'Does one shape look bigger?'</i></p> 

4:7

To finish this teaching point, show children a variety of shapes that could be manipulated to make complete rectangles. This will support children's visualisation skills as they discuss ideas about how the shapes could be altered. Begin to discuss how you can count the squares efficiently. For example, for the first shape shown opposite, once children have made the shape into a complete rectangle, they could count row by row in steps of five. Some children might recognise that they can use five times table facts. This will be developed further in *Teaching point 6*.

Adjusting shapes to make complete rectangles:

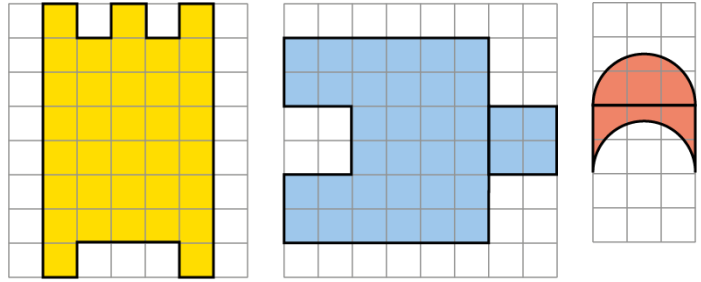

Teaching point 5:

Area is measured in square units, such as square centimetres (cm^2) and square metres (m^2).

Steps in learning

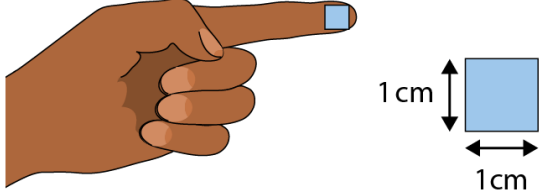
	Guidance	Representations
5:1	<p>This teaching point focuses on the use of a standard measure that is universally recognised. In step 4:6 children learnt that if you are to compare areas you must use the same-sized squares.</p> <p>Using sticky notes, cut out squares that are $1\text{ cm} \times 1\text{ cm}$. Tell children that this is one square centimetre, which is written as 1 cm^2. Point out that it approximately covers the pad on the end of their index finger, which they can use as a benchmark for estimating area.</p> <p>Use this square to estimate the area of a variety of real-life objects such as books, calculators or plates, so that children don't just associate area with shapes in books. This step will develop children's estimation skills.</p>	
5:2	<p>Remind children that one square centimetre is a unit of area and that other units are also used. Discuss the idea that when you count squares people need to know which sized square you are using, so you put the unit after the number to show this. Work towards the following generalised statement: 'We can measure area in square centimetres. We write this as "cm^2".'</p>	
5:3	<p>Using centimetre squared grids, ask children to estimate the area of various shapes, and then work out the exact area. Ensure that children use the unit of square centimetres in their answers.</p>	

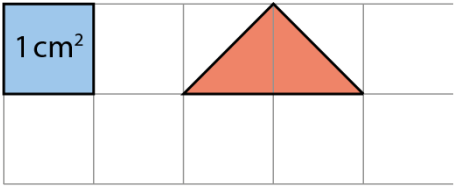
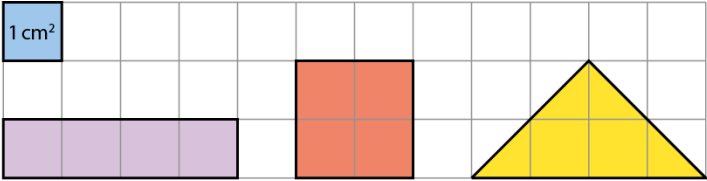
<p>5:4</p>	<p>When learning to use a square centimetre to measure area, children must not overgeneralise and think that this is the only shape that has an area of one square centimetre. Show the children some other shapes that also have an area of one square centimetre.</p> <p>To build on this point you may like to show children other shapes that have an equal area but are different shapes, such as the examples given opposite. Return to the idea that the scale must always be given so that we know the actual size.</p>	<p>Representing 1 cm²:</p>  <p>Different shapes with the same area:</p>  <p style="text-align: center;">4 cm² 4 cm² 4 cm²</p>
<p>5:5</p>	<p>Repeat steps 5:1–5:4 using metres instead of centimetres and introduce the unit m². You could use large sheets of paper to measure shapes drawn on the playground in chalk.</p>	

Teaching point 6:

The area of a rectangle can be calculated using multiplication; the area of a composite rectilinear shape can be found by splitting the shape into smaller rectangles.

Steps in learning

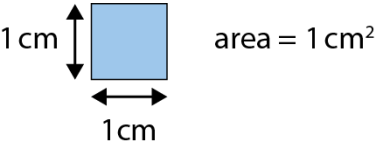
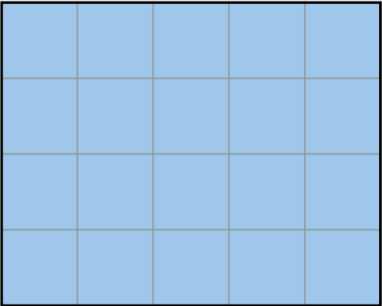
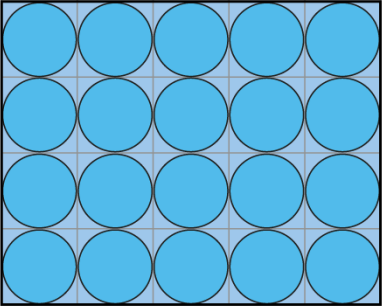
	Guidance	Representations
6:1	<p>Show children an image of a 5 cm × 4 cm rectangle and explain that you need to calculate its area. Explain that you are going to count the squares, using counters to mark as you go. Count together and agree that the area is 20 cm².</p> <p>Introduce the use of 'A' to mean 'area'.</p>	<p><i>'How many squares are there?'</i></p>  <p style="text-align: center;">1 cm area = 1 cm² 1 cm</p>   <ul style="list-style-type: none"> <i>'There are twenty 1 cm squares, so A = 20 cm².'</i>

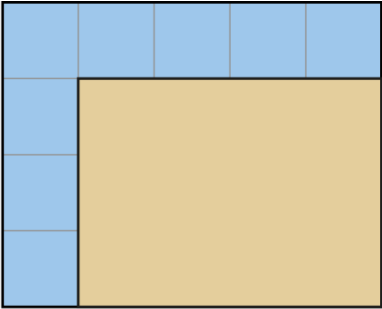
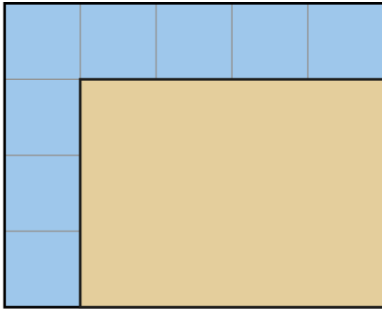
<p>6:2</p>	<p>Remove the counters from the rectangle and ask children if they have any ideas of how you could calculate the area without counting the squares one by one. Give children some time to explore, and direct them towards the idea that they could use their knowledge of arrays and multiplication to calculate the area.</p> <p>Discuss with children whether they could count in fours or in fives, coming to the conclusion that they could count in either.</p>	
<p>6:3</p>	<p>Now progress this to show that not all of the squares need to be shown in order to calculate the area of the rectangle. We can calculate the area using just one row of the length and one column of the width. You could show this by hiding the rest of the squares with a plain piece of paper cut to size.</p>	<p>Calculating the area using side-lengths:</p> 
<p>6:4</p>	<p>Use multiplication to show children how to calculate the area. Place the factors in both positions:</p> $5 \text{ cm} \times 4 \text{ cm} = 20 \text{ cm}^2$ $4 \text{ cm} \times 5 \text{ cm} = 20 \text{ cm}^2$ <p>Make sure children know what each number represents using the following stem sentence: 'The ___ represents the ___.'</p> <p>Work towards the following generalised statement: 'To find the area of a rectangle multiply the length by the width.'</p> <p>It doesn't matter which side children choose as the length and which they choose as the width because the answer will always be the same (as shown above).</p>	<p>'What is the area of this rectangle?'</p>  <p> $5 \text{ cm} \times 4 \text{ cm} = 20 \text{ cm}^2$ $4 \text{ cm} \times 5 \text{ cm} = 20 \text{ cm}^2$ $A = 20 \text{ cm}^2$ </p> <ul style="list-style-type: none"> • 'The "5 cm" represents the width.' • 'The "4 cm" represents the length.' • 'The "20 cm²" represents the area.'

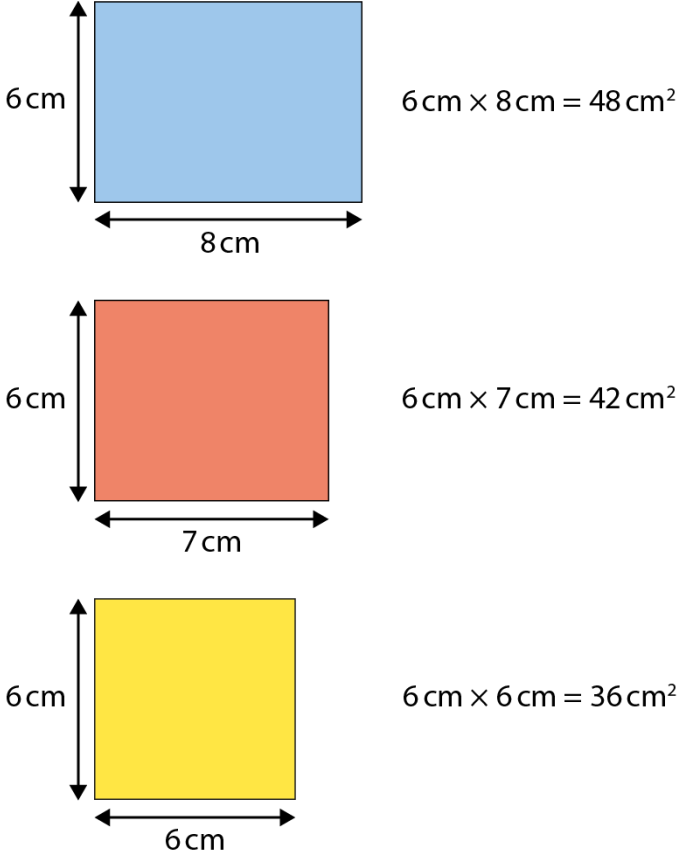
<p>6:5</p>	<p>Use the generalised statement in step 6:4 to work out the area of different rectangles.</p> <p>Start by showing children a series of rectangles with the same length, but a width that decreases in increments of 1 cm. Ask children to use the generalised statement from the previous step to work out the areas of the rectangles. Once you have worked out the areas, ask children if they can see a link to a times table. Encourage them to see that the pattern of answers follows a times table.</p>	<p>Using multiplication to calculate the area of rectangles:</p>  <p>6 cm \times 8 cm = 48 cm²</p> <p>6 cm \times 7 cm = 42 cm²</p> <p>6 cm \times 6 cm = 36 cm²</p>
<p>6:6</p>	<p>Encourage children to apply their knowledge to finding areas of rectangles in real-life contexts. You could use rulers or tape measures to measure rectangular objects in the classroom and then calculate the areas.</p>	

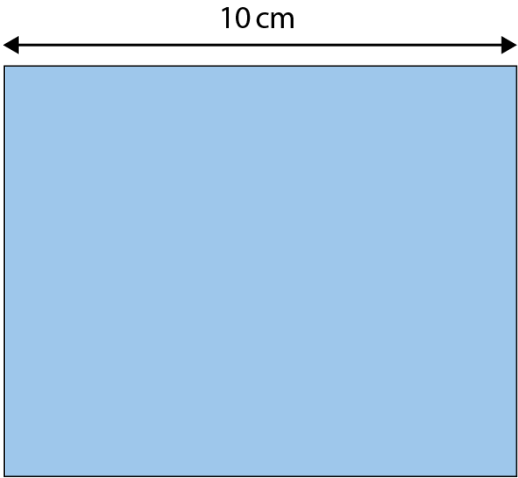
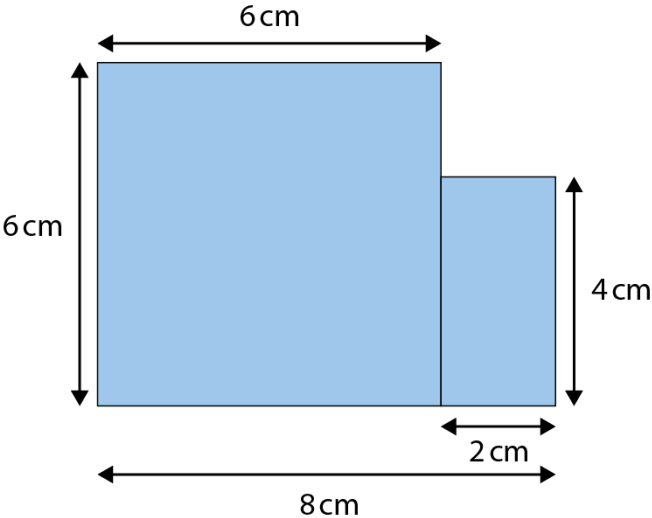
<p>6:7</p>	<p>Next develop these skills by showing a rectangle and providing the area and one side-length, and asking children to use division to work out the missing side-length. The process is similar to that used in step 3:4 for finding missing dimensions when given the perimeter. Use division to work out the unknown side:</p> <p style="padding-left: 20px;">$\text{area} \div \text{known side} = \text{unknown side}$</p> <p>Repeat this step using different rectangles, providing the area and one side.</p>	<p><i>'The area of this rectangle is 80 cm^2. How long is the short side?'</i></p>  <p>$A = 80 \text{ cm}^2$ $80 \div 10 = 8$ short side = 8 cm</p>
<p>6:8</p>	<p>Now explore finding the area of rectilinear shapes using rectangles. First, show children a shape that is made up of two rectangles of different sizes. Ask them how they could work out the area. Discuss the idea of splitting the shape into two rectangles and working out the area of each rectangle, and then adding the areas together.</p> <p>Next show children the same shape and explore a different way to work out the area. Show children that you can add a third rectangle to make one large shape, and then work out the area of the large shape. You then subtract the area of the third rectangle to find the answer to the original problem.</p>	<p>Finding the area using two rectangles: <i>'What is the area of this shape?'</i></p>  <p>$A = 6 \text{ cm} \times 6 \text{ cm} + 2 \text{ cm} \times 4 \text{ cm} = 44 \text{ cm}^2$</p>

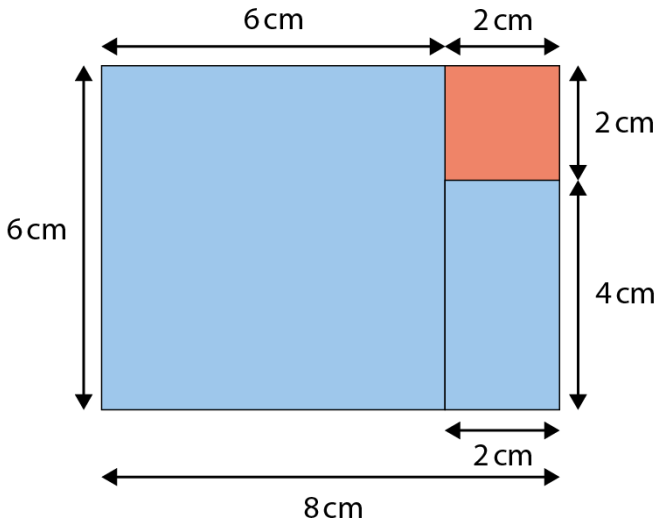
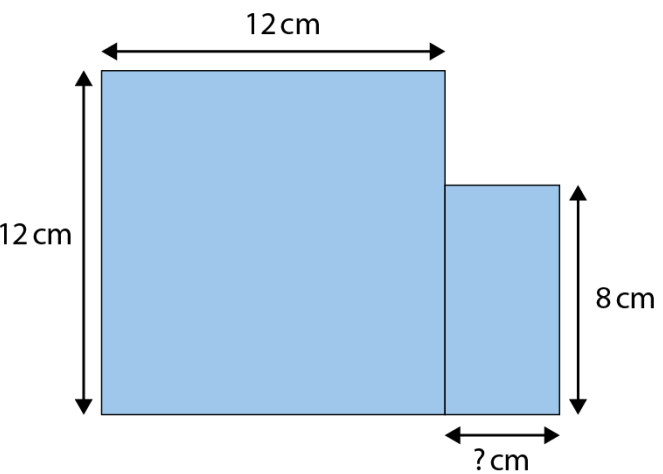
		<p>Finding the area by making one large rectangle: <i>'What is the area of this shape?'</i></p>  <p>$A = 8 \text{ cm} \times 6 \text{ cm} - 2 \text{ cm} \times 2 \text{ cm} = 44 \text{ cm}^2$</p>
<p>6:9</p>	<p>To complete this teaching point provide children with practice finding the areas of rectangles, including:</p> <ul style="list-style-type: none"> • missing-number problems • true/false style problems • missing-symbol problems (to indicate which shape has a larger area). <p>You may like to use 'what's the same? what's different?' questions to highlight that shapes can have the same area but different perimeters.</p>	<p>Using known values to find a missing side-length:</p> <ul style="list-style-type: none"> • <i>'The area of this shape is 176 cm². Find the length of the missing side.'</i>  <p>$A = 176 \text{ cm}^2$</p> <p>$12 \times 12 + \square \times 8 = 176 \text{ cm}^2$</p>

- 'Here is a T-shape made from three identical rectangles. The area of the shape is 90 cm^2 . What is the length of the missing side?'

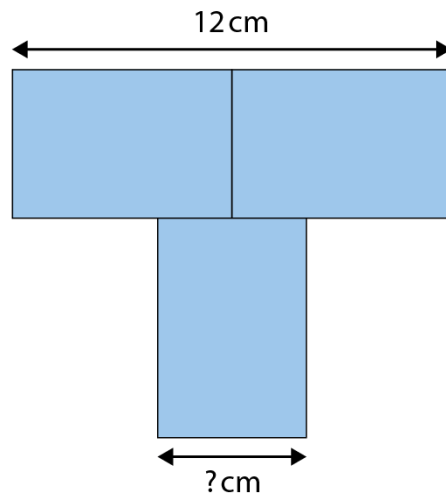

True/false style problems:

'Is the following statement true or false?'

area of rectangle A $>$ area of rectangle B

'Explain your reasons.'

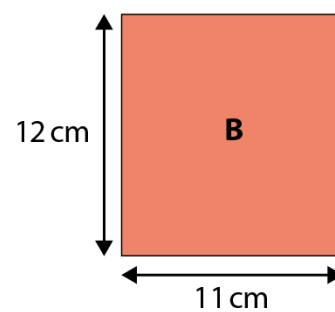
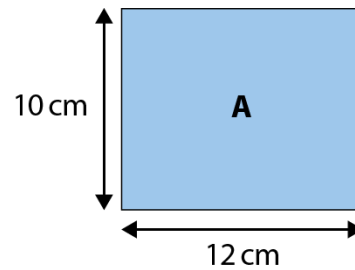

Comparing area and perimeter:

'Each square has side-length of 6 cm.'

- *'What is the area of shape A?'*
- *'What is the area of shape B?'*
- *'What is the perimeter shape A?'*
- *'What is the perimeter of shape B?'*

- *'What's the same?'*

- *'What's different?'*

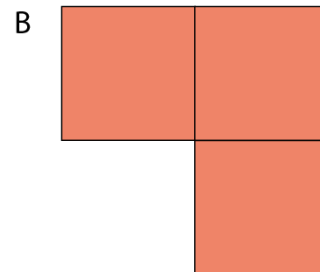
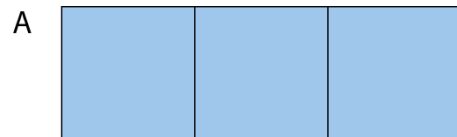

Dòng nǎo jīn:

'This picture frame has an area of 48 cm². What could the dimensions of the outer rectangle and the inner rectangle be?'

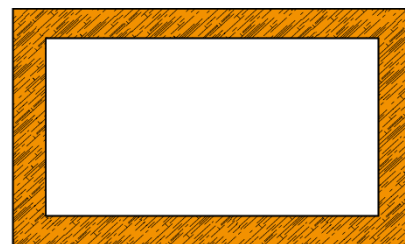

Not to scale